

# Lead-Free\* 250 PSI CWP Iron Body Grooved Silent Check Valves

Twin Disc • Grooved Style • Bronze Disc • Buna-N Seat • Spring Actuated

**250 PSI/17.2 bar non-shock cold working pressure**  
**Maximum temperature to 180°F/82°C at 220 PSI/15 bar**

CERTIFIED LEAD-FREE\* BY WQA TO NSF/ANSI 372  
CONFORMS TO ANSI/AWWA C606 FOR STEEL IPS PIPE



**C USA**  
**COMPONENT LEAD-FREE**



**G-920-W-LF**  
Grooved

## MATERIAL LIST

PART	SPECIFICATION
1. Body	Ductile Iron ASTM A536 Grade 65-45-12 w/Buna-N (Nitrile) resilient seat molded to body
2. Disc	Bronze ASTM B584 Alloy C87600
3. Torsion Spring	Stainless Steel ASTM A313 UNS S31600
4. Disc Hinge Pin	Stainless Steel ASTM A276 UNS S31600
5. Disc Stop Pin	Stainless Steel ASTM A276 UNS S31600
6. Disc Thrust Bearing	Stainless Steel ASTM A240 UNS S31600
7. Hinge Pin Retainer	Steel
8. Stop Pin Retainer	Steel
9. Stabilization Sphere	Buna-N
10. Spacer	Stainless Steel ASTM A276 UNS S31600

Sizes 10" and 12" furnished with lifting eyebolt

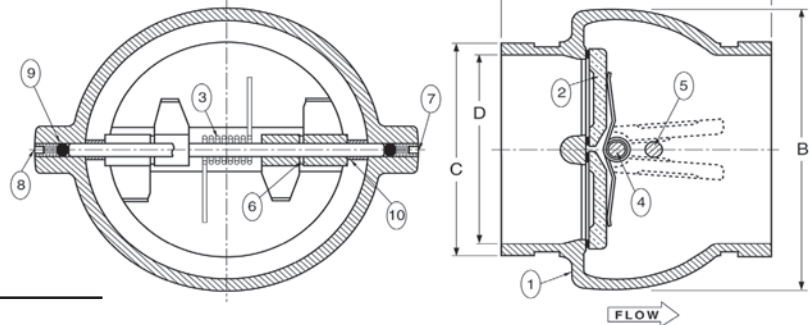

## DIMENSIONS—WEIGHTS

Size	Dimensions								Weight		
	A		B		C		D		Lbs.	Kg.	
In. mm.	In.	mm.	In.	mm.	In.	mm.	In.	mm.			
2	50	4.66	111	4.13	105	2.38	60	2.00	51	3.30	1.49
2½	65	4.91	125	4.88	124	2.88	73	2.41	61	4.50	2.04
3	80	5.31	135	5.38	137	3.50	89	2.94	75	7.30	3.31
4	100	5.38	137	6.00	152	4.50	114	3.91	99	8.60	3.90
5	125	5.72	145	7.06	179	5.56	141	4.89	124	13.00	5.90
6	150	6.00	152	8.13	206	6.63	168	5.92	150	18.00	8.17
8	200	6.72	171	10.03	255	8.63	219	7.91	201	30.00	13.6
10	250	7.78	198	12.38	314	10.75	273	10.00	254	56.00	25.4
12	300	8.19	208	14.38	365	12.75	324	11.94	303	81.80	36.7

Groove dimensions conform to ANSI/AWWA specification C606 Table 4 (Cut Groove Dimensions)

**NOTE:** Twin Disc Check Valves can be installed horizontally or in the vertical position with flow up.

**CAUTION:** For horizontal flow applications, the valve must be installed with disc hinge pin in the vertical position to insure proper operation.

- WARNING:**
1. This valve is not to be used as a steam valve.
  2. Valves are not to be used near a reciprocating air compressor.
  3. Install 5 pipe diameters minimum downstream from pump discharge or elbows to avoid flow turbulence. Flow straighteners may be required in extreme cases.

**Note:** On pump discharge, the preferred check valves are:  
- inline, spring assisted, center-guided, lift checks  
- spring assisted twin (double) disc  
- swing design with lever and weight or lever and spring

Install 5 pipe diameters minimum downstream from pump discharge or changes in direction to avoid flow turbulence. Flow straighteners may be required in extreme cases.

\*Weighted average lead content ≤ 0.25%

Visit our website for the most current information.



**WARNING:** This product can expose you to chemicals including lead, which is known to the State of California to cause cancer and birth defects or other reproductive harm. For more information go to [www.P65Warnings.ca.gov](http://www.P65Warnings.ca.gov).